

KE CRANE

HENAN WEIKE XIWEN INDUSTRIAL CO., LTD

 : www.kecrane.com

 : info@kecrane.com

 : +86 18137827089

 : Zhengzhou, Henan Province



Crane Parts Introduction

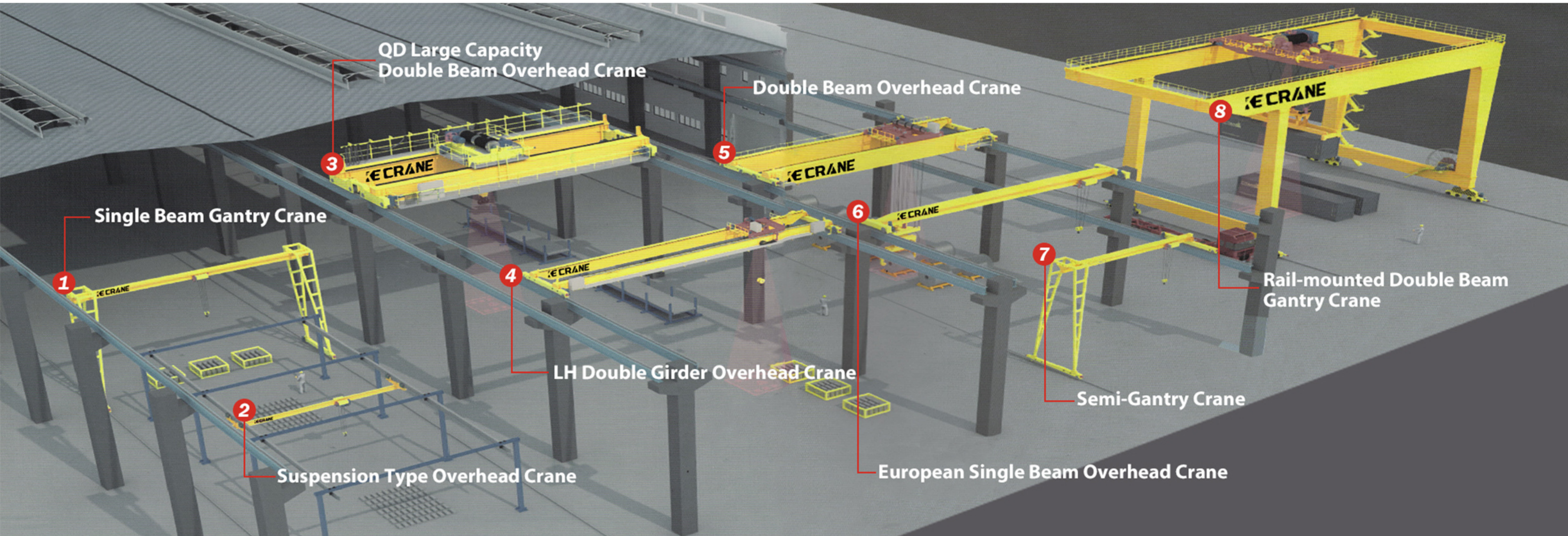

COMPANY PROFILE

KE Crane is a professional crane manufacturer integrating R&D, manufacturing, sales, installation and service. With a wide range of products and a global selection of raw materials, we are committed to providing custom designed material handling solutions for both standard and custom cranes.

We have served more than 6,000 customers in over 100 countries and territories worldwide. Industries served include over 50 key industry sectors such as aerospace, automotive and marine, steel smelting, petrochemical, electronics and information technology, power and water conservancy, and military rail, and our products have been operating effectively and safely. We promise to provide a 12-month warranty and permanent technical service support for all our products.

Our factory covers an area of 1.62 million square metres and has more than 4,500 employees, including more than 200 senior engineers and technicians. There are more than 20 production workshops with more than 3,500 sets of various advanced processing equipment and product test benches. We use globally selected raw materials to improve product quality to the maximum extent while reducing costs. We provide R&D, production, sales and services for more than 110 types of cranes and accessories such as gantry cranes, overhead cranes, electric hoists, lifting electromagnets and lifting grabs. We can provide total solutions and whole life cycle services for our customers and are committed to the intelligent, environmentally friendly and high quality development of the crane industry.

OUR FACTORY



QUALIFICATION CERTIFICATE



PRODUCT CATALOG

Lifting Spreader

C Shape Steel Coil Hook Lifter.....	1
Crane Hook Assembly.....	2
Steel Lifting Spreader Beam.....	3
Container lifter.....	4

Lifting clamp

Electric Rotary Clamp.....	5
Steel Lifting Clamp.....	6

Crane Wheel

European Crane Wheel.....	7
Forged Steel Rail Wheels For Crane.....	8
Crane Trolley Wheel Set.....	9

Crane Coupling

Crane Coupling.....	10
---------------------	----

Cable Reel

Spring Cable Reel.....	11
Motor Cable Reel.....	12

Remote Controller

F21 Series Remote Control.....	13
F23 Series Remote Control.....	14
F24 Series Remote Control.....	15
F24-60 Joystick Remote Control.....	16

Brake

Brake.....	17
------------	----

Overhead Crane End Beam

Overhead Crane End Beam.....	18
------------------------------	----

Electric Power line

Over Head Crane Power Supply Bus Bar.....	19
Rubber Sheathed Cable.....	20

LIFTING SPREADER

C Shape Steel Coil Hook Lifter

◆ **Basic Parameter:**

Work Load Limit: 3t~30t
Inner Height(mm): 450~850
The Diameter Of Inner Coil (mm):
≥560
Itself Weight (kg): 350~3400

Steel Coil Lifting C Hook Crane Parts is mainly used for the horizontal lifting of the coiled plate. Because its shape resembles the literal C, it is called a C-type spreader.

The structure is simple and reasonable, the action is flexible, the use is convenient, and the lifting is safe and reliable.

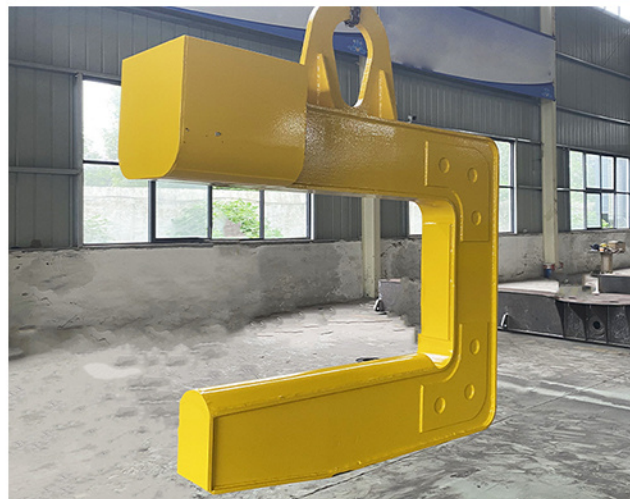

Crane Hook Assembly

◆ **Basic Parameter:**

Color: Yellow or Customized
Capacity: 0.5t-500t
Material: Casting Steel / Forging Steel
Application: Hoist, Winch, Trolley and Crane
Warranty: 12 months
Rope: 2/4 ropes
Self-Weight: 80-500Kg
Drawing: Available on Request



Industrial hoist hooks is one of the most suitable slings in hoisting. It is connected with pulleys to hang on the wire rope of lifting mechanism. And the hook is the most widely usage when lifting cargos. It is made easily and operated practically.

The structure is simple and reasonable, the action is flexible, the use is convenient, and the lifting is safe and reliable.

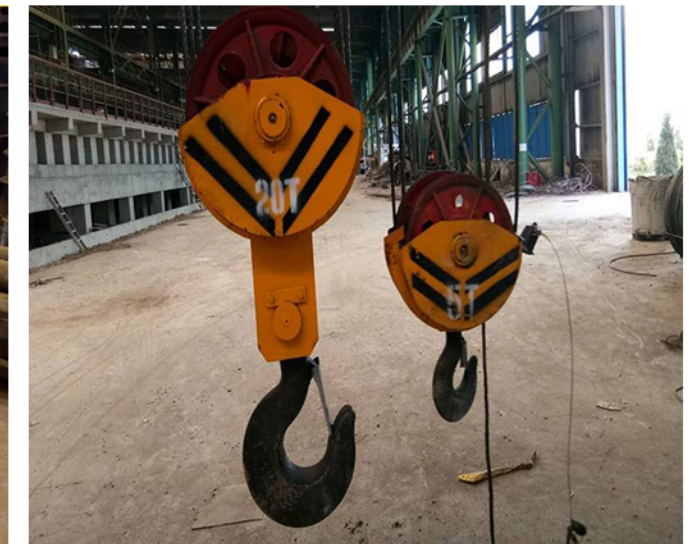

Steel Lifting Spreader Beam

Steel Lifting beam can be used to lift and move a wide range of industrial loads. The hooks on both ends can be adjusted to any location you want. Lifting beam is a good choice when the headroom is limited and restricts the use of overhead rigging in the application. Lifting beam is usually made from a beam and a single lifting point at the top with several lift points at the bottom. A lifting beam is a type of equipment used for lifting and handling heavy objects, usually consisting of hooks, ropes, slings, chains, rings, rods, hangers, etc.

◆ **Basic Parameter:**

Load capacity range: 2-40 tons

Beam material: high-quality low-carbon alloy structural steel

Beam structure: box shaped, streamline curved surface

Beam accessories: pin shaft, eye hook (rotating hook)



Container lifter

Container lifter is a kind of machinery and equipment widely used in the field of container logistics, which is mainly used for container handling, loading and unloading and transportation. Its working principle is to lift and transfer the container through a number of actions such as start, stop, lift, lower, extend, shrink and rotate, and deliver it safely to the destination. It is a widely used in logistics transportation, port terminals and other fields of machinery and equipment, through the control of the lifting mechanism, to achieve the container lifting, moving and transfer and other actions. It can improve the efficiency of logistics transportation, reduce the consumption of human resources, and meet the diversified needs of the market.

◆ **Basic Parameter:**

Specifications: customizable

Load: customizable

Applicable scope: Machinery, chemicals, ships, docks, etc

Material: container

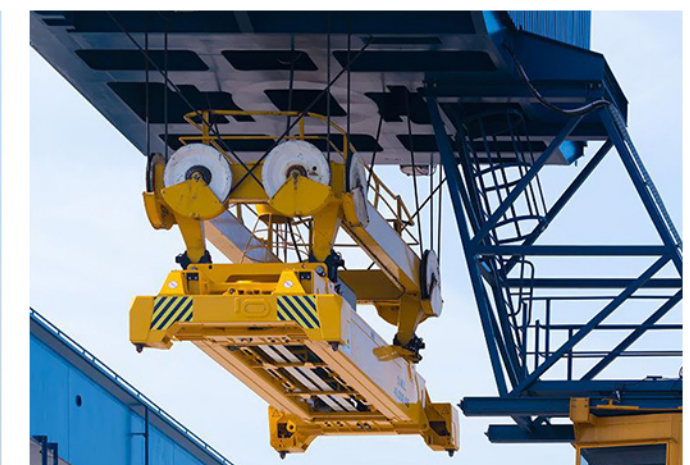
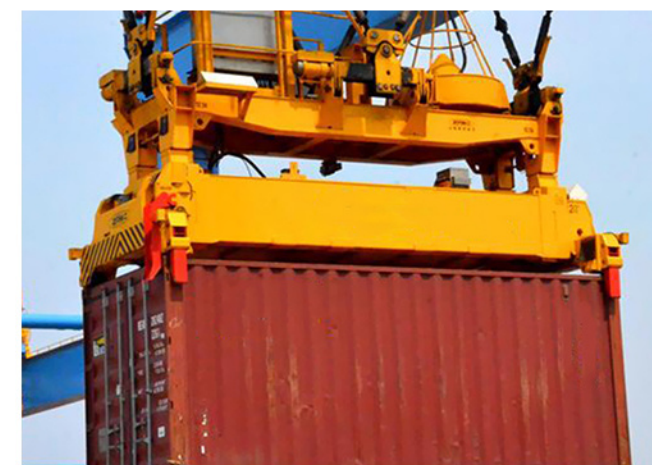

LIFTING CLAMP

Electric Rotary Clamp

It is mainly composed of clamp frame, mechanical mechanism, electrical control system, cable drum and other parts. 1. Clamp frame: The main part of the electric steel coil clamp is spliced by steel plate (high-quality low-alloy steel), and the cross-section is a box-shaped structure, which has good anti-bending and torsional performance, making the clamp lightweight. 2. Mechanical mechanism: adjust the opening size of the clamp hoisting range through the mechanical mechanism.



◆ **Basic Parameter:**

Material: Low carbon alloy steel
 Maximum load: 35 (TON)
 Function: Clamp sleeve, round steel or steel billet



Steel Lifting Clamp

The steel billet lifting fixture uses the lever principle to lift the steel billet, without the need for a power source. It is positioned and locked by a rotating automatic locking device or mechanical automatic locking device. It can lift single-layer and multi-layer steel billets and has the characteristic of flexible operation. The billet clamp mainly consists of seven parts: a lifting beam, a connecting rod, an automatic locking device, a synchronizer, a clamp arm, a support plate, and a clamp tooth.

◆ **Basic Parameter:**

Capacity: 5T-40T
 Hooks: Aluminum / Steel

Sizes: Customized size
 Function: Heavy Material Transport



Crane Trolley Wheel Set

The wheel group is a mechanical equipment composed of wheels, shafts, bearings, and bearing boxes. It is generally used to support a crane and load on a vehicle, and together on a designated track, it is a device that allows the crane to move back and forth.

The application of wheel sets is quite complex, and different skill methods are selected based on different product structures. However, the focus of the wheel group is still on controlling the horizontal deviation value of the working wheel group. A commonly used and relatively simple planning structure in daily work is to assemble wheels onto brackets to form a wheel group.

The composition of the wheel group is generally made of high-quality cast steel, because the common damage methods for wheels are wear, pitting, and crushing of the hardened layer. Therefore, in order to increase the wear resistance and service life of the wheel surface, materials with relatively solid and deep quenching are generally used.

◆ **Basic Parameter:**

Wheel Diameter: 200-800 mm
Wheel Material: Forged steel

Weight: 70-300 kg
Color: Customized



CRANE COUPLING

Crane Coupling

A coupling is a component that axially connects two shafts and transmits torque and motion, and has the ability to compensate for the deviation of the two shafts. In order to reduce vibration in the mechanical transmission system and reduce impact peak loads, the coupling also has certain cushioning and shock absorption performance. Sometimes, the coupling also has overload safety protection. It has the ability to compensate for radial, axial, and angular axis deviations, and has the advantages of compact structure, small turning radius, large bearing capacity, low transmission noise, and long maintenance cycle.

◆ **Basic Parameter:**

Nominal torque(KN·m): 0.71 – 1000
Allowable speed(r/min): 3780 – 300

Weight(kg): 12.8 – 6010
Inertia(kg·m²): 0.03 – 568



CABLE REEL

Spring Cable Reel

◆ **Basic Parameter:**

- Length: 10-100m
- Cable: 3*0.75mm²
- Rating: 380V
- Material: Standard Copper
- Rated Voltage: Rated Voltage

JT series cable reel is a mechanical device that introduces the internationally-used wind-up type cable reel technology, uses a volute spring as the power, and uses the energy of the spring to automatically rewind the cable. It is suitable for various places that require mobile cable power supply, such as lifting electromagnets, electric flatbed carts, various cranes, hydraulic grabs, etc.

Applicable cables: power cables with a cross-sectional area of less than 35 m² and signal cables with a core area of less than 24 m².

Winding length: not exceeding 30m.



Motor Cable Reel

◆ **Basic Parameter:**

- Rated Voltage: 220V – 440V
- Rated Current: 10A – 16A
- Frequency: 50Hz – 60Hz
- Material: fire-retardant PP housing
- Cable Specifications: crane cable specs

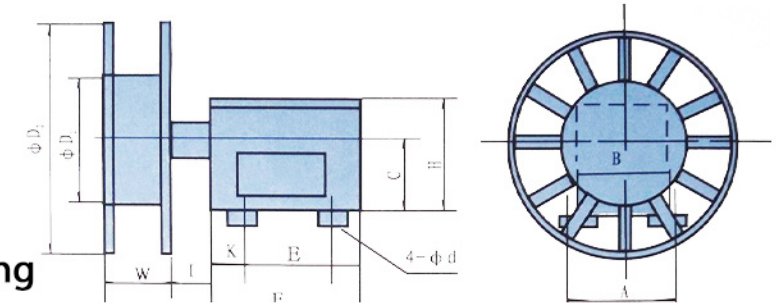

Motor cable reel is a winding device used for large mobile starting equipment to transmit power, control power, or control signals between two relatively moving bodies. It is widely used in heavy machinery equipment such as port gantry cranes, container cranes, ship loaders, tower cranes, and other similar working conditions.

The main engine is composed of a gearbox, a power head, and a collector slip ring box as a whole. The power head consists of an electric motor, a hysteresis coupling, and a planetary gearbox. According to different working conditions, single or multiple power heads can be used as the driving force for the hysteresis cable reel. The collector slip ring box is the power (signal) transmission part, which can be divided into power transmission and signal transmission according to its purpose, and can be divided into 500V, 3KV, 6KV, 10KV, 20KV, etc. according to voltage levels.



REMOTE CONTROLLER

F21 Series Remote Control

The remote control is suitable for hoisting machinery, engineering machinery, construction machinery, loading/unloading machinery, lifts, truck cranes, winch equipment, lifting platforms, hydraulic and pneumatic equipment, fire-fighting equipment, railway bridges and tunnel construction and various human control is not and is not allowed. Wire-controlled electronic control equipment. It is used to enhance the safety and reliability of equipment, improve the working environment, reduce labor intensity and improve work efficiency.

◆ **Basic Parameter:**

- Button: 8 buttons
- Control distance: 100m
- Battery Type: AA
- Protection class: IP65
- Receiving End Voltage: 24/36/220/360V

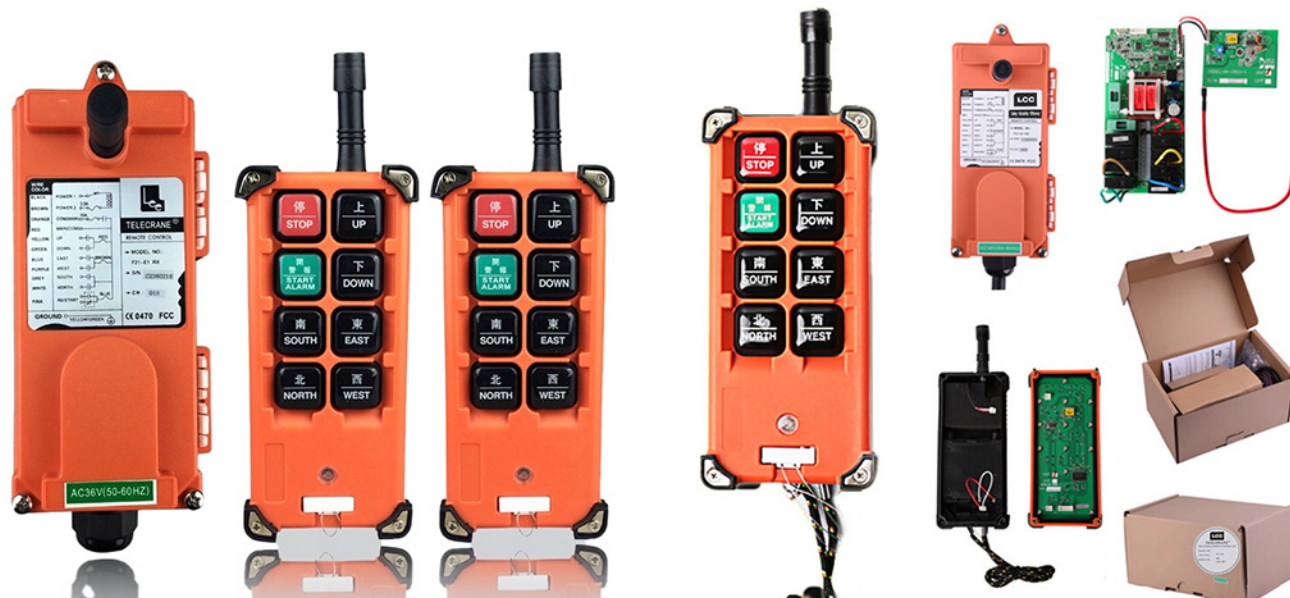

F23 Series Remote Control

F23 series adds 4 multi-function buttons, which can set different functions as required, so as to be applicable to a variety of different working scenarios. The remote control is suitable for hoisting machinery, engineering machinery, construction machinery, loading/unloading machinery, lifts, truck cranes, winch equipment, lifting platforms, hydraulic and pneumatic equipment, fire-fighting equipment, railway bridges and tunnel construction and various human control is not and is not allowed. Wire-controlled electronic control equipment. It is used to enhance the safety and reliability of equipment, improve the working environment, reduce labor intensity and improve work efficiency.

◆ **Basic Parameter:**

- Button: 12 buttons
- Control distance: 100m
- Battery Type: AA
- Protection class: IP65
- Receiving End Voltage: 24/36/220/360V



F24 Series Remote Control

F24 series products add emergency stop function buttons and variable speed control function, which is applicable to lifting hoists with variable speed function. Various voltages can be switched at will, and the voltage can be converted according to customer needs. Comfortable feel and reliable performance. Equipped with high-performance antennas to effectively improve wireless signal performance.

◆ **Basic Parameter:**

Button: 8/10 buttons
Battery Type: AA

Control distance: 100m
Protection class: IP65



F24-60 Joystick Remote Control

The product is equipped with two five speed rocker, all-round operation, emergency stop button and safety key switch. It is suitable for a variety of different double beam cranes. Various voltages can be switched at will, and the voltage can be converted according to customer needs. Comfortable feel and reliable performance. Equipped with high-performance antennas to effectively improve wireless signal performance.

◆ **Basic Parameter:**

Button: 14 buttons
Battery Type: AA

Control distance: 100m
Protection class: IP65



Brake

For the crane lifting operation, the braking device is mainly to avoid the fall of the boom and the lifting object, to avoid the crane and the turntable to slide due to the component force and wind force of the ramp, to avoid the deceleration of the mechanism in operation, and finally stop moving. Widely used in industries such as lifting and transportation, port machinery, metallurgical machinery, railway machinery, hydraulic machinery, mining machinery, etc.

◆ Usage Conditions

Environmental temperature -20 °C~+50 °C

The relative temperature of the air shall not exceed 90%

The surrounding environment must not contain flammable, explosive, or corrosive gases.

The altitude of the location of use complies with GB755-2000

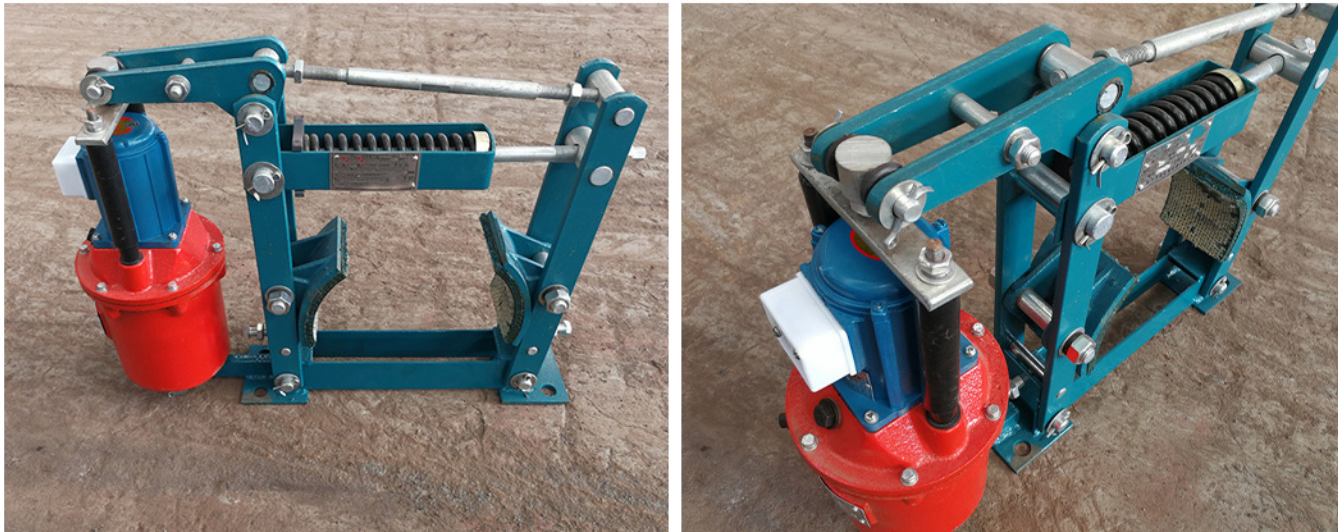

Overhead Crane End Beam

◆ Basic Parameter:

Working Speed : 20/30 m/min

Power: 0.8~1.5Kw

Voltage: 380V 50HZ Three-phase

Work Duty: A3~A5



Single Beam End Beam For Bridge Crane is composed by Wheels, motors, buffers, collector base, girder joint plate and bolts, etc. The end beam adopts rectangular control, CNC boring and milling integrated customized machine tool, a one-time completion of opening, boring, drilling. Equipped with high quality reducer, hollow shaft drive, high working level, wide speed adjustment range, widely popular.



ELECTRIC POWER LINE

Over Head Crane Power Supply Bus Bar

◆ **Basic Parameter:**

Poles: 3/4/6

Max. Current (A): 140

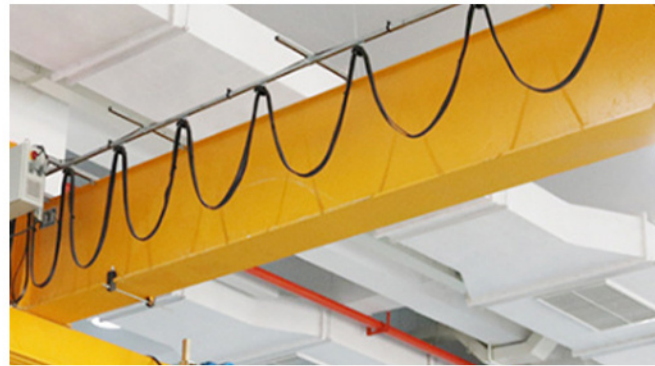

Crane seamless bus bar crane conductor rail wire is made with high quality raw materials:

Conductive material: 99.99% Oxygen-free copper

Housing material: PVC (heat resistance property 70°C – -40°C below)

Ensure stable use, long life, suitable for all kinds of bridge cranes.



Rubber Sheathed Cable

◆ **Basic Parameter:**

Jacket: CPE rubber or PCP rubber

Voltage: 300/500V or 450/750V

Number of cores: 1,2,3,4,5

Type: Insulated

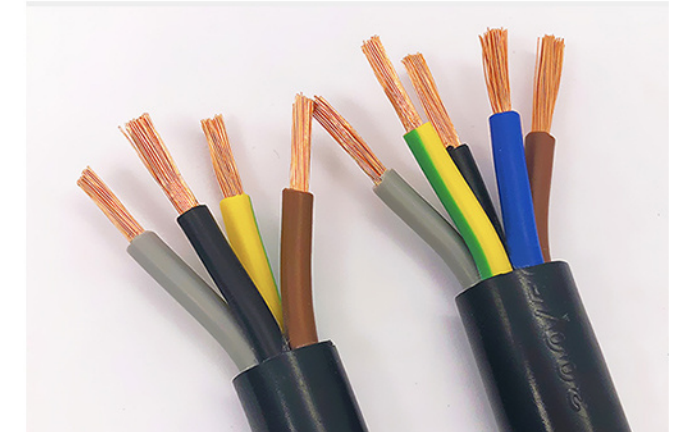

Rubber sheathed cable is a soft and movable cable type made of multi-stranded thin copper wires as conductors, covered with rubber insulation and rubber sheath. Generally speaking, it includes general rubber-sheathed flexible cables, welding machine cables, submersible motor cables, radio device cables and photography light source cables, etc.

The crane control cable is suitable for outdoor, indoor, dry or moist industry sites. In order to suit for installation, the flat cable should apply to the follows properties: highly flexible, minimal bending radius, oil resistance, acids and alkalis resistance. It is mainly used in large traveling crane, conveyor machinery, tower crane, overhead crane, outdoor building lift, trailing shaft of crane or others similar machines parts.

